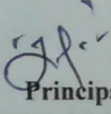

4.3.3 Available bandwidth of internet connection in the Institution (Broadband Connection)

Sr.No	Bandwidth of Broadhand connection (Internet)	LAN configuration and speed (Intranet)
1	Omkar Infotech Pvt.Ltd Latur: 50 MBPS Sky Communication Latur: 10 MBPS (Broadband)	
2	Public IP address : 103.25.155.34 (Omkar Info.) Public IP address : 103.89.41.125 (Sky Communication)	Private IP address: 172.16.1.2 to 172.16.3.254
3	Public Gateway : 103.25.155.33 (Omkar Info.) Public Gateway : 103.48.59.142 (Sky Communication)	Private Gateway: 172.16.1.1
4	Speed: 60 MBPS	Speed: 100/1024 MBPS
5	Domain Name: cocsit.org.in	

Principal
Cocsit Latur
College of Computer Science
and Information Technology, Latur

Royal Education Society's

College of Computer Science and Information Technology (COCSIT), Latur.

Block Diagram of Network

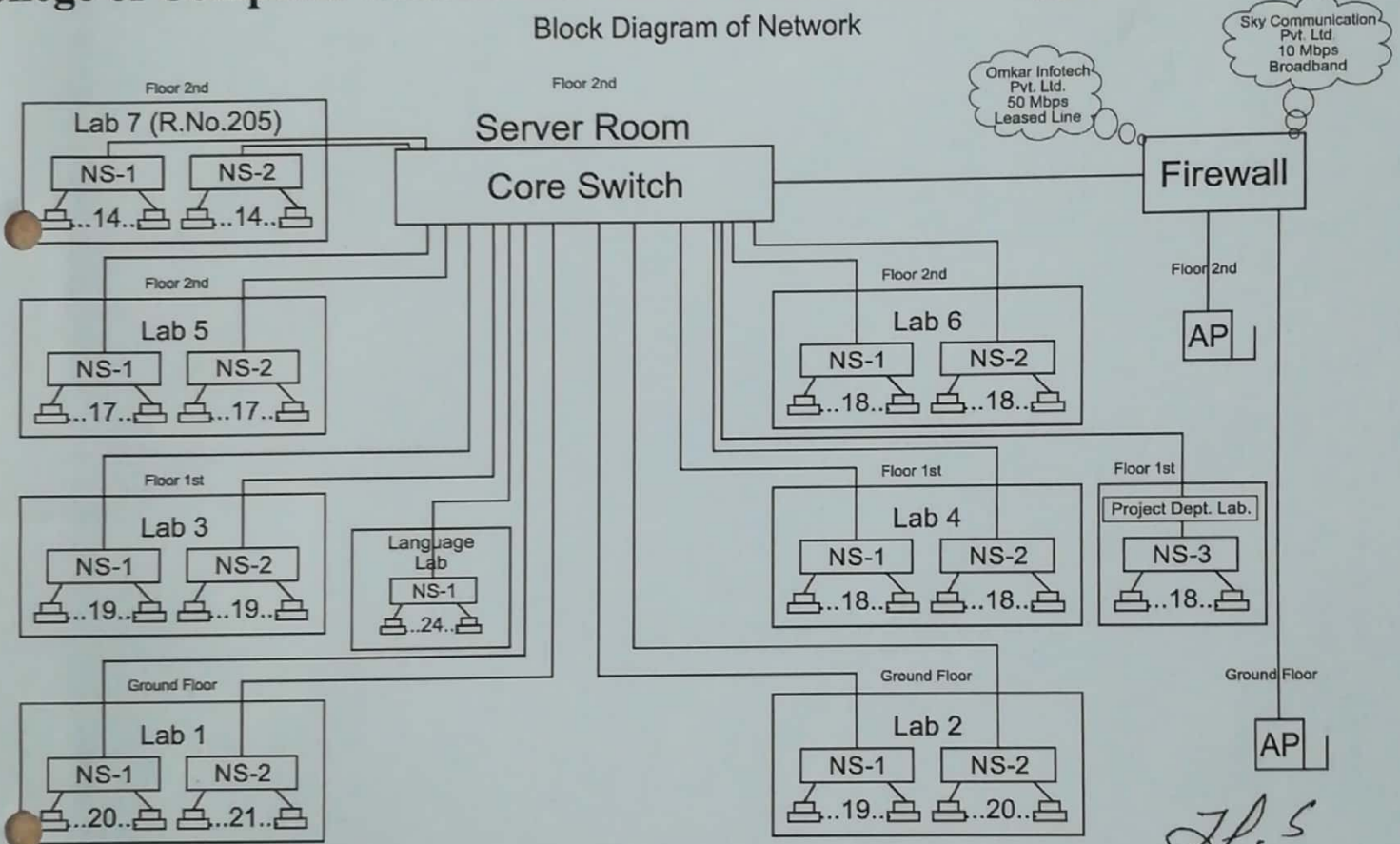

Handwritten signature



Handwritten signature
PRINCIPAL
College of Computer Sci. & Information Technology
Ambajogal Road, LATUR-413631

SKY COMMUNICATION

INVOICE

Sky Tv Network ,
Amey Plaza Nandi Stop ,
LATUR - 413512
9422072700 . 02382-253366
skytvlatur@gmail.com
GSTIN 27AECPS8850C1ZD

DATE	12-10-18
INVOICE #	376
PAYMENT	
Sales Man	Jadhav

Subscriber

The Principal Cocsit
Latur

DESCRIPTION	Quantity	AMOUNT
1) Plan 10 Mbps Period(12 Oct-18 To 11 Nov-18)		1,200.00

Subtotal	1,200.00
CGST 9%	108.00
SGST 9%	108.00
TOTAL	1416.00

Amount (in words)
One Thousand Four Hundred Sixteen Rupes Only
Terms :
1. Goods once sold will not be taken back or exchanged.
2. We are not responsible for any type of warranty if company denied.

Sky Communication!
For Sky Communication
Proprietor
Authorized Signatory

This is Computer Generated invoice
Thank You For Your Business!



Royal Education Society's

[Govt. of Maharashtra approved, affiliated to S.R.T. Marathwada University, Nanded and included under Section 2(f) and 12(B) of U.G.C. Act 1956]



COLLEGE OF COMPUTER SCIENCE AND INFORMATION TECHNOLOGY(COCSIT), LATUR

संगणकशास्त्र व माहितीतंत्रज्ञान महाविद्यालय(कॉक्सिट), लातूर.

Ambajogai Road, LATUR-413531 (Maharashtra)

COCSIT

Ph.: 02382-229191, Fax : 02382-228646, Website : www.cocsit.org.in, E-mail : cocsit365@rediffmail.com

Ref. No.: COCSIT/2016-17/

Date : 09-12-2016

Dr. N. S. Zulpe

M.C.S., M.Phil., Ph.D.

Principal

Cell : 9970763030

PURCHASE ORDER

To,
M/s. SUJATA COMPUTERS PVT. LTD.
PUNE

This refers to our requirement for **Cyberoam** Renewal. **PURCHASE ORDER** as per below

Sr. No.	Product Description	Total
1.	CR 25 ING Total Value Subscription Plus (For 3Year) =1	28,000
	Service Tax 15%	4,200
	VAT 6%	1,932
	GRAND TOTAL	34,132

TERMS & CONDITIONS

DELIVERY	Delivery within 1 working week after PO
PAYMENT	60 day credit
TAXES	As mentioned above
OCTROI	NOT Applicable

YOURS FAITHFULLY

N. S. Zulpe

(Dr. N. S. Zulpe)

PRINCIPAL

College of Computer Sci. & Information Technology

Ambajogai Road, LATUR-413531



TAX INVOICE

Registered Office SUJATA COMPUTERS PVT.LTD. 66/2, Guruchhaya Apartment, Nal Stop, Karve Road, Pune 411004 CIN No. U30007PN1999PTC013578 Email: Accounts@sujataindia.Com Phone: (020)40100300 Website: Www.Sujataindia.Com CIN NO:	Invoice No. OP-OS\14338	Dated 20-Dec-2016
	Delivery Note	Mode/Terms of Payment 60 DAYS
	Supplier's Ref. SUHAS G.-14338	Other Reference(s)
	Buyer's Order No. COCSIT/2016-17/	Dated 9-Dec-2016
	Quotation ID	Dated
Billed From: SUJATA COMPUTERS PVT. LTD. Gat No.2332, House No.398, Ubale Nagar, Near Gayatri Packing, Wagholi,Dist-Pune-412207. E-Mail :accounts@sujataindia.com	Despatched through E-LIC DELIVERY VIA E-MAIL	Destination
Buyer (if other than consignee) College of Computer Science and Information Technology(COCSIT), Ambajogai Road, Latur-413531	Salesman Name. Suhas Gugale	
City : LATUR State : Maharashtra Contact Person : Dr. N. S. Zulpe Mob : 9970763030 Email : Cocsit365@rediffmail.Com	Despatch Details College of Computer Science and Information Technology(COCSIT), Ambajogai Road, Latur-413531 City : LATUR State : Maharashtra Contact Person : Dr. N. S. Zulpe Mob : 9970763030 Email : Cocsit365@rediffmail.Com	

SI No.	Description of Goods	Part No.	Quantity	Rate	per	Disc. %	Amount
1	TOTAL VALUE SUBSCRIPTION CYBEROAM 25 ING REN 3YR S/N. SAG000051523-ZKULSE (Service : Information Technology Software Service)	06-TVSP-RNL-0026RNG-03	1 NOS.	28,000.00	NOS.		28,000.00
	Service Tax (On Assessable Amount 28,000.00)				14 %		3,920.00
	Swachh Bharat Cess (0.50%)				0.50 %		140.00
	Output Krishi Kalyan Cess (0.50%)				0.50 %		140.00
	Vat Output 6%				6 %		1,932.00
Total			1 NOS.				₹ 34,132.00

Amount Chargeable (in words)

Rupee Thirty Four Thousand One Hundred Thirty Two Only

E. & O.E

Remarks:

BALANCE (30 DAYS) (SAME AS ABOVE)

Company's VAT TIN : **27360026425V**
Company's CST No. : **27360026425C**
Company's Service Tax No. : **AADCS9203MST001**
Buyer's VAT TIN : **NA**
Buyer's CST No. : **NA**
Company's PAN : **AADCS9203M**

Declaration

I/We hereby certify that my/our Registration Certificate under the Maharashtra Value Added Tax Act, 2002 is in force on the date on which the sales of the goods specified in this TAX INVOICE is made by/us and that the transaction of sale covered by this TAX INVOICE has been effected by me/us and it shall be accounted for in the turnover of sales while filing of return and the due tax, if any, payable on the sales has been paid or shall be paid.

Terms & Conditions

- 1) Warranty Is From Product Principals
- 2) Cheque Return Charges Applicable As Per Cheques Amount, Overdue 48% P.A.
- 3) No Complaints Will Be Entertained on Short of Material/ Breakages Once It Leaves Our Premises. So Please Check Carefully.
- 4) Ownership of Item Invoiced Will Only Transfer After Receipt of Full Payment
- 5) We Provide Assembled PC Systems Only with FORMATED HDD

Company's LBT No. :

Date & Time : **20-Dec-2016 at 20:01**

for SUJATA COMPUTERS PVT. LTD.

Authorised Signatory

This is a Computer Generated Invoice



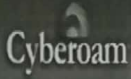

CR25ING - 18.6.3 Beta-1

Dashboard Wizard Report Console Logout

Dashboard

- SYSTEM
- OBJECTS
- NETWORK
- WIRELESS PROTECTION
- IDENTITY
- FIREWALL
- VPN
- IPS
- WEB FILTER
- APPLICATION FILTER
- WAF
- IM
- QoS
- ANTI VIRUS
- ANTI SPAM
- TRAFFIC DISCOVERY
- LOGS & REPORTS

Alert Messages

- ! 2:06 New Firmware available. Refer [Release Notes](#) for upgrade procedure. [Click here](#) to download the new firmware.
- ! 16-Oct HTTP,Telnet based management is allowed from the WAN. This is not a secure configuration. We recommend using a good password.
- ! 16-Oct HTTPS,SSH based management is allowed from the WAN. This is not a secure configuration. We recommend using a good password.
- Jan-2016 Keeping in pace with Industry Standards, we have increased RSA hostkey length to support 2048-bit encryption. [Click and continue with SSH connection](#) if you receive a warning for a changed fingerprint from SSH Client. more

Appliance Information

Appliance Key	C06113230665-QVVF9T
Model Number	CR25ING
Firmware Version	10.6.3 Beta-1 [Check for Upgrades]
Firmware Build	076
IPS Signature Version	3.15.32
Anti Virus Version	3.74.0.5.55
Webcat Signature Version	0.0.4.110
Application Signatures	4.15.32

Gateway Status

Gateway Name	Gateway IP Address	Status
cocsit_gateway	103.25.155.33	●
skynet	103.48.59.142	●

System Status

System Time	Sat 27 Oct 2018 12:01:14
Up Time	10 days, 18 hours, 43 minutes
Live Connected Users	33

System Usage

CPU usage for last two hours

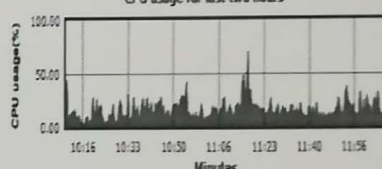

Memory usage for last two hours

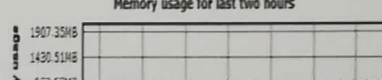

Status :

